

SURFACE MOUNT PRODUCTS : TAPE & REEL DIMENSIONS

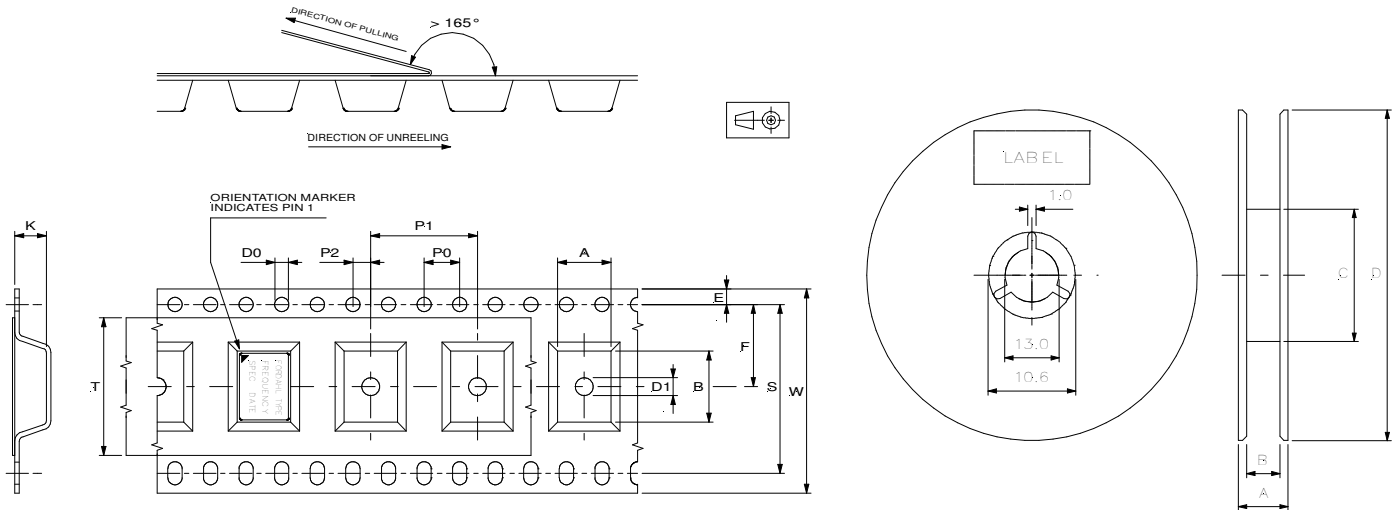

Materials: Carrier tape : conductive polycarbonate
 Cover tape : polyester, antistatic coated
 Reel : conductive or antistatic treated polystyrene

| Product type | Oscil. | Tape [mm] | | | | | | | | | | | | | MOQ [pcs] | Reel [mm] | | | | |
|--------------|---------------------|-----------|------|------|------|------|------|------|-----|------|-----|------|------|-----|-----------|-----------|------|------|-----|-----|
| | | A | B | E | F | K | S | T | W | D0 | D1 | P0 | P1 | P2 | | A | B | C | D | |
| S1 | PXO VCXO TCXO | 9.4 | 15 | 1.75 | 11.5 | 6.25 | - | 21.3 | 24 | 1.55 | 2.0 | 4.0 | 12 | 2.0 | 250 | 27.8 | 24.7 | 60 | 180 | |
| | | | | | | | | | | | | | | | 1000 | 30.5 | 26.1 | 100 | 330 | |
| S2 | PXO VCXO TCXO | 5.5 | 8.7 | | 7.5 | 3.6 | - | 13.3 | 16 | | 1.5 | | 8 | | 200 | 500 | 19.8 | 16.7 | 60 | 180 |
| | | | | | | | | | | | | | | | | 2000 | 21.4 | 17.0 | 100 | 330 |
| S4 | TCXO | 26.5 | 26.5 | | 20.2 | 7.5 | 40.4 | 37.5 | 44 | | 1.0 | | 32 | | 200 | 49.6 | 45.2 | 100 | 330 | |
| S7 | VCXO TCXO | 13.2 | 20.2 | | 14.2 | 8.0 | 28.4 | 25.3 | 32 | | 2.0 | | 20 | | 450 | 39.6 | 35.2 | 100 | 330 | |
| S8 | PXO | 13.2 | 20.2 | 14.2 | 5.3 | 28.4 | 25.3 | 32 | 2.0 | 20 | 600 | 39.6 | 35.2 | 100 | 330 | | | | | |

Please consult factory for details on S5, S11, S15, S16 and S17

NOTICE:

1. Storage

Please store the products in room where temperature / humidity is stable. Conditions should be:
 Temperature: 5 to 35°C
 Humidity: 30 to 60% RH
 If products are stored for more than a year, solderability may be degraded. Please confirm it regularly.

2. Transportation

If you transport the products, please pack them so that the package will not be damaged by mechanical vibration / shock and please educate and guide a carrier to prevent rough handling.